

EnEV 730.02
ErP 812/2013
ErP 814/2013
SIA 384/1

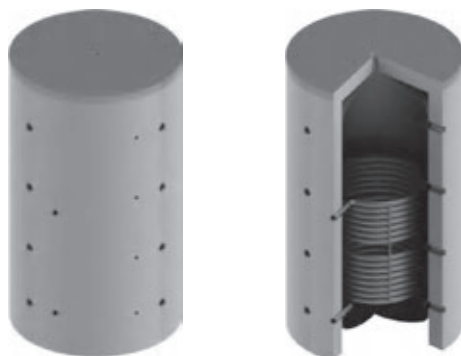

Bauart

Design | Structure | Struttura

Die Speicher werden aus hochwertigem Stahl nach EN 10025:2019 gefertigt.

EN The storage tanks are made from high quality steel in accordance with EN 10025:2019.

FR Les ballons sont fabriqués en acier de grande qualité, selon la norme EN 10025:2019.

IT Gli accumulatori sono realizzati in acciaio pregiato secondo la norma EN 10025:2019.

Betriebsdruck / Prüfdruck	3 bar / 4.5 bar
Operating pressure / test pressure Pression de service / Pression test Pressione d'esercizio / Pressione di collaudo	
Einsatzgebiet	18°C – 95°C
Application Application Applicazione	

Schutz vor Korrosion

Anti-corrosion protection | Protection contre la corrosion | Protezione anticorrosiva

Innen sind die Speicher unbehandelt. Aussen sind die Speicher grundiert.

EN The storage tanks are untreated on the interior. Tanks are primed on the outside.

FR À l'intérieur, les réservoirs ne sont pas traités. A l'extérieur, les réservoirs sont apprêtés.

IT L'interno degli accumulatori non è trattato. Gli accumulatori sono primerizzati all'esterno.

Wärmetauscher

Heat exchanger | Échangeur de chaleur | Scambiatore di calore

Ein eingeschweisster grossflächiger Wärmetauscher.

EN One welded large-surface heat exchanger.

FR Un échangeur de chaleur grande surface soudé.

IT Uno scambiatore di calore saldato di grande superficie.



Isolierung

Insulation | Isolation | Isolamento

TopShell

Isolierung aus Hightech Faservlies. Skaimantel mit Reißverschluss, inklusive Rosetten und Abdeckhaube. Brandschutzklasse B2. Silber. Lose geliefert.

Variante

Isolierung aus Hightech Faservlies. PS-Mantel und Hakenleiste, inklusive Rosetten und Abdeckhaube. Brandschutzklasse B2. Farbe Silber.

EN TopShell

Insulation made of high-tech fibre fleece. Skai jacket with zip, including cover plates and hood. Fire-resistance rating B2. Silver. Supplied loose.

Alternative

Insulation made of high-tech fibre fleece. PS jacket and hook rack, including cover plates and hood. Fire-resistance rating B2. Silver.

FR TopShell

Isolation en tissu fibreux high-tech Enveloppe en skai avec fermeture à glissière, y compris rosettes et capot. Classe allemande de protection incendie B2. Argent. Livrée non montée.

Alternative

Isolation en tissu fibreux high-tech Enveloppe en PS équipée d'un support à crochets préinstallé, y compris rosettes et capot. Classe allemande de protection incendie B2. Couleur argent.

IT TopShell

Isolamento in tessuto non tessuto high-tech. Mantello in skai pre-assemblato con cerniera, dotato di rosette e calotta di copertura. Classe di resistenza antincendio B2. Argento. Consegna sfusa.

Alternativa

Isolamento in tessuto non tessuto high-tech. Mantello in PS e barra con ganci, rosette e calotta di copertura incluse. Classe di resistenza antincendio B2. Colore argento.

TopShell
B2; $\lambda = 0.038 \text{ W/(mK)}$

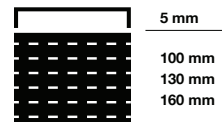



Pufferspeicher

Buffer storage tanks

Ballon tampon

Accumulatori tampone

Verwendung Usage Utilisation Uso		500	600	800	900	1000	1050	1250	1500	1600	1800	1950	2000	2500	3000	4000	5000
TopShell 100	Wärmeverlust Heat losses Pertesthermiques Perdita di calore	kWh/24h	2.61	2.89	3.12	3.38	3.38	3.49	3.82	-	-	-	-	-	-	-	-
		W	109	121	130	141	141	146	160	-	-	-	-	-	-	-	-
	ErP-Label ErP class Classe ErP Classe ErP	C	C	C	C	C	C	C	C	-	-	-	-	-	-	-	-
	CH SIA 384/1 Ta ≤ 90°C	X	•	•	•	•	•	•	X	X	X	X	X	X	X	X	X
	CH SIA 384/1 Ta ≤ 50°C	X	•	•	•	•	•	•	X	X	X	X	X	X	X	X	X
	EU Nr. 814/2013 (EU)	•	•	•	•	•	•	•	X	X	X	•	•	•	•	•	•
	A  [mm]	1680	1700	1740	1820	2090	2050	2060	2200	1950	2205	2060	2420	2330	2770	2885	2920
	C Ø [mm]	850	900	990	1050	990	1050	1150	1200	1300	1300	1450	1300	1450	1450	1600	1800
	Art. Nr. 300106... Part no. Réf. Art.n.	0501	0601	0801	0901	1001	1051	1251	1501*	1601*	1801	1951	2001	2501	3001	4001	5001
	TopShell 130	Wärmeverlust Heat losses Pertesthermiques Perdita di calore	kWh/24h	-	-	-	-	-	-	4.00	4.08	4.35	-	-	-	-	-
		W	-	-	-	-	-	-	167	170	182	-	-	-	-	-	
ErP-Label ErP class Classe ErP Classe ErP		-	-	-	-	-	-	-	C	C	C	-	-	-	-	-	
CH SIA 384/1 Ta ≤ 90°C		X	•	•	•	•	•	•	•	•	•	X	X	X	X	X	
CH SIA 384/1 Ta ≤ 50°C		X	•	•	•	•	•	•	•	•	•	X	X	X	X	X	
EU Nr. 814/2013 (EU)		•	•	•	•	•	•	•	•	•	•	•	•	•	•	•	
A  [mm]		1710	1730	1770	1850	2120	2080	2090	2230	1980	2235	2090	2450	2360	2800	2915	
C Ø [mm]		910	960	1050	1110	1050	1110	1210	1260	1360	1360	1510	1360	1510	1510	1660	
Art. Nr. 300106... Part no. Réf. Art.n.		0502*	0602*	0802*	0902*	1002*	1052*	1252*	1502	1602	1802*	1952*	2002*	2502*	3002*	4002*	
TopShell 160		Wärmeverlust Heat losses Pertesthermiques Perdita di calore	kWh/24h	-	-	-	-	-	-	-	-	-	-	-	-	-	-
		W	-	-	-	-	-	-	-	-	-	-	-	-	-	-	
	ErP-Label ErP class Classe ErP Classe ErP	-	-	-	-	-	-	-	-	-	-	-	-	-	-	-	
	CH SIA 384/1 Ta ≤ 90°C	X	•	•	•	•	•	•	•	•	•	X	X	X	X	X	
	CH SIA 384/1 Ta ≤ 50°C	X	•	•	•	•	•	•	•	•	•	•	•	•	•	•	
	EU Nr. 814/2013 (EU)	•	•	•	•	•	•	•	•	•	•	•	•	•	•	•	
	A  [mm]	1740	1760	1800	1880	2150	2110	2120	2260	2010	2265	2120	2480	2390	2830	2945	
	C Ø [mm]	970	1020	1110	1170	1110	1170	1270	1320	1420	1420	1570	1420	1570	1570	1720	
	Art. Nr. 300106... Part no. Réf. Art.n.	0503*	0603*	0803*	0903*	1003*	1053*	1253*	1503*	1603*	1803*	1953	2003	2503	3003	4003	

Ta = Auslegungstemperatur

Ta = dimensioning temperature | Ta = température de conception | Ta = temperatura di progetto

 Zugelassen (Empfohlene Isolierung)
Approved (Recommended insulation) | Agréée (Isolation recommandée) | Omologato (Isolamento consigliato)

 Zugelassen (oberhalb Mindestanforderung)
Approved (Exceeds minimum requirements) | Agréée (Supérieure aux exigences minimales requises) | Omologato (Requisito minimo superiore)

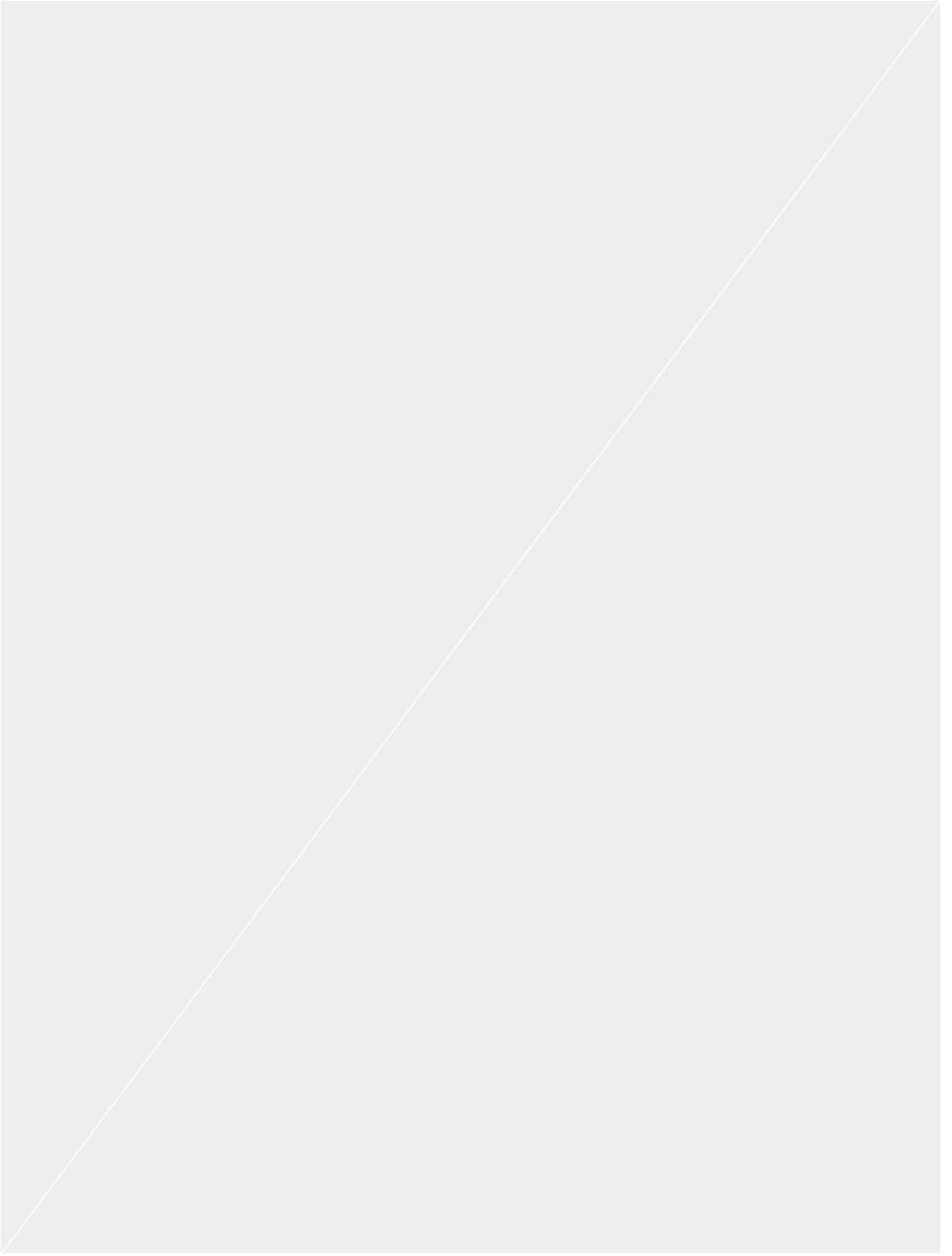

Pufferspeicher
Buffer storage tanks
Ballon tampon
Accumulatori tampone

500 – 5000

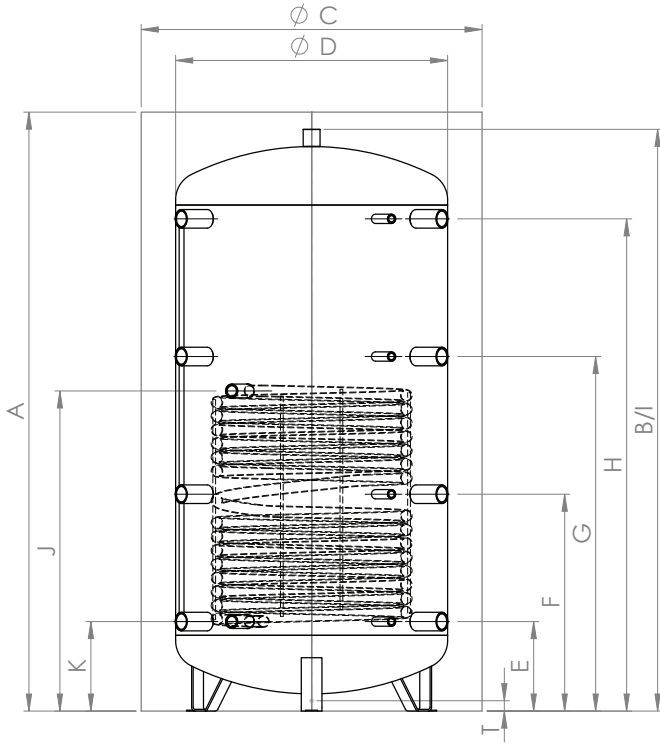

500 – 5000

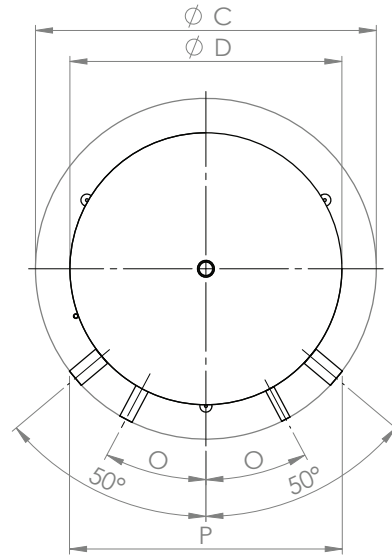

500 – 5000



Verwendung Usage Utilisation Uso		Dimension Dimension Dimensione	500	600	800	900	1000	1050	1250	1500	1600	1800	1950	2000	2500	3000	4000	5000
Inhalt Capacity Contenance Contenuto		l	480	560	718	870	887	996	1266	1500	1555	1830	2005	2021	2304	2852	3759	5003
Glattrohrwärmetauscher Heating coil Échangeurs de chaleur Serpentino		m ²	2.3	1.8	2.8	3.1	3.1	3.1	3.1	3.6	3.7	3.7	3.0	4.2	4.2	4.2	5.4	6.1
		l	15.1	11.8	18.3	20.3	20.3	20.3	20.3	23.6	24.3	24.3	19.7	27.5	27.5	27.5	35.3	39.9
Kippmass Tilted dimension Cote de basculement Altezza in raddrizzamento		mm	1650	1680	1720	1800	2070	2020	2030	2180	1940	2190	2050	2390	2310	2740	2880	2920
P	Einbringmass Delivery dimensions Cote de mise en place Ingombro	100 mm	690	730	800	840	800	840	950	1000	1100	1100	1250	1100	1250	1250	1400	1600
		130 mm	740	780	840	890	840	890	970	1010	1100	1100	1250	1100	1250	1250	1400	1600
		160 mm	780	820	890	940	890	940	1010	1060	1130	1130	1250	1130	1250	1250	1400	1600
B	Höhe ohne Isolierung Height without insulation Hauteur sans isolation Altezza senza isolamento	mm	1620	1650	1685	1770	2040	1990	1998	2148	1902	2152	2007	2352	2267	2704	2835	2870
D	Ø ohne Isolierung without insulation sans isolation senza isolamento	mm	650	700	790	850	790	850	950	1000	1100	1100	1250	1100	1250	1250	1400	1600
E*	Anschluss 1 Connection Raccord Collegamento	- mm	220	230	260	310	310	310	310	380	320	320	495	320	535	380	505	400
		G"	1 1/2"	1 1/2"	1 1/2"	1 1/2"	1 1/2"	1 1/2"	1 1/2"	2"	2"	2"	2"	2"	2"	2"	2"	2"
		- G"	1/2"	1/2"	1/2"	1/2"	1/2"	1/2"	1/2"	1/2"	1/2"	1/2"	1/2"	1/2"	1/2"	1/2"	1/2"	1/2"
F*	Anschluss 2 Connection Raccord Collegamento	- mm	620	610	630	700	745	745	745	825	740	820	875	900	975	1020	1110	1100
		G"	1 1/2"	1 1/2"	1 1/2"	1 1/2"	1 1/2"	1 1/2"	1 1/2"	2"	2"	2"	2"	2"	2"	2"	2"	2"
		- G"	1/2"	1/2"	1/2"	1/2"	1/2"	1/2"	1/2"	1/2"	1/2"	1/2"	1/2"	1/2"	1/2"	1/2"	1/2"	1/2"
G*	Anschluss 3 Connection Raccord Collegamento	- mm	1010	990	1030	1080	1250	1250	1250	1350	1150	1320	1255	1490	1415	1680	1860	1810
		G"	1 1/2"	1 1/2"	1 1/2"	1 1/2"	1 1/2"	1 1/2"	1 1/2"	2"	2"	2"	2"	2"	2"	2"	2"	2"
		- G"	1/2"	1/2"	1/2"	1/2"	1/2"	1/2"	1/2"	1/2"	1/2"	1/2"	1/2"	1/2"	1/2"	1/2"	1/2"	1/2"
H*	Anschluss 4 Connection Raccord Collegamento	- mm	1385	1380	1430	1470	1710	1710	1710	1760	1570	1820	1635	2020	1855	2330	2410	2520
		G"	1 1/2"	1 1/2"	1 1/2"	1 1/2"	1 1/2"	1 1/2"	1 1/2"	2"	2"	2"	2"	2"	2"	2"	2"	2"
		- G"	1/2"	1/2"	1/2"	1/2"	1/2"	1/2"	1/2"	1/2"	1/2"	1/2"	1/2"	1/2"	1/2"	1/2"	1/2"	1/2"
I	Anschluss oben Connection above Raccord du haut Collegamento superiore	- mm	1620	1650	1685	1770	2040	1990	1998	2148	1902	2152	2007	2352	2267	2704	2835	2870
		G"	1 1/4"	1 1/4"	1 1/4"	3/4"	1 1/4"	1 1/4"	1 1/4"	1 1/4"	1 1/4"	3/4"	1 1/4"	1 1/4"	1 1/4"	1 1/4"	1 1/4"	
J	VL Glattrohrwärmetauscher Heating coil Échangeurs de chaleur Serpentino	- mm	850	860	930	990	1030	990	1015	1180	970	1020	1025	1120	1250	1430	1555	1580
		G"	1"	1"	1"	1"	1"	1"	1"	1"	1"	1"	1"	1"	1"	1"	1"	1"
K	RL Glattrohrwärmetauscher Heating coil Échangeurs de chaleur Serpentino	- mm	220	230	260	310	310	310	300	380	320	370	495	320	535	480	505	580
		G"	1"	1"	1"	1"	1"	1"	1"	1"	1"	1"	1"	1"	1"	1"	1"	1"
T	Bodenmuffe Ground fitting Manchon de fond Manicotto a pavimento	- mm	-	-	-	-	-	-	-	-	-	-	123	-	123	110	75	50
		G"	-	-	-	-	-	-	-	-	-	-	1 1/4"	-	1 1/4"	1 1/4"	1 1/4"	1 1/4"
O	Anordnung Fühler Positioning sensor Disposition sonde Disposizione sensore	°	23.5	28.0	28.0	29.8	28.0	29.8	32.0	33.0	34.5	34.5	36.0	34.5	36.0	36.0	37.5	39.0
Gewicht Weight Poids Peso		kg	113	111	138	150	157	161	204	222	227	240	256	264	303	350	446	523
Art.Nr. 100 mm 200105... Part no. Réf. Art.n.			0501	0601	0801	0901	1001	1051	1251	1501	1601	1801	1951	2001	2501	3001	4001	5001
Art.Nr. 130 mm 200105... Part no. Réf. Art.n.			0502	0602	0802	0902	1002	1052	1252	1502	1602	1802	1952	2002	2502	3002	4002	5002
Art.Nr. 160 mm 200105... Part no. Réf. Art.n.			0503	0603	0803	0903	1003	1053	1253	1503	1603	1803	1953	2003	2503	3003	4003	5003
Max. Einbaulänge von Elektroheizungen Max. installation length of electric heaters Longueur maximale d'installation des chauffages électriques Lunghezza massima di installazione dei riscaldatori elettrici		mm	650	700	790	850	790	850	950	1000	1100	1100	1250	1100	1250	1250	1400	1600

*Einbaumöglichkeit: 1 x Elektroheizung zum Einschrauben
Installation option: 1 x Screw-in Immersion heater | Option d'installation: 1 x Résistances à visser | Opzione di installazione: 1 x Resistenza elettrica da avvitare