

**EnEV 730.02**  
**ErP 812/2013**  
**ErP 814/2013**  
**SIA 384/1**



**Bauart**  
**Design | Structure | Struttura**

Die Speicher werden aus hochwertigem Stahl nach EN 10025:2019 gefertigt.

**EN** The storage tanks are made from high quality steel in accordance with EN 10025:2019.

**FR** Les ballons sont fabriqués en acier de grande qualité, selon la norme EN 10025:2019.

**IT** Gli accumulatori sono realizzati in acciaio pregiato secondo la norma EN 10025:2019.

<b>Betriebsdruck / Prüfdruck</b> Operating pressure / test pressure   Pression de service / Pression test   Pressione d'esercizio / Pressione di collaudo	3 bar / 4.5 bar
<b>Einsatzgebiet</b> Application   Application   Applicazione	18°C – 95°C

**Schutz vor Korrosion**  
**Anti-corrosion protection | Protection contre la corrosion | Protezione anticorrosiva**

Innen sind die Speicher unbehandelt. Aussen sind die Speicher grundiert.

**EN** The storage tanks are untreated on the interior. Tanks are primed on the outside.

**FR** À l'intérieur, les réservoirs ne sont pas traités. A l'extérieur, les réservoirs sont apprêtés.

**IT** L'interno degli accumulatori non è trattato. Gli accumulatori sono primerizzati all'esterno.



## Isolierung

Insulation | Isolation | Isolamento

### TopShell

Isolierung aus Hightech Faservlies. Skaimantel mit Reissverschluss, inklusive Rosetten und Abdeckhaube. Brandschutzklasse B2. Silber. Lose geliefert.

### Variante

Isolierung aus Hightech Faservlies. PS-Mantel und Hakenleiste, inklusive Rosetten und Abdeckhaube. Brandschutzklasse B2. Farbe Silber.

### EN TopShell

Insulation made of high-tech fibre fleece. Skai jacket with zip, including cover plates and hood. Fire-resistance rating B2. Silver. Supplied loose.

### Alternative

Insulation made of high-tech fibre fleece. PS jacket and hook rack, including cover plates and hood. Fire-resistance rating B2. Silver.

### FR TopShell

Isolation en tissu fibreux high-tech Enveloppe en skai avec fermeture à glissière, y compris rosettes et capot. Classe allemande de protection incendie B2. Argent. Livrée non montée.

### Alternative

Isolation en tissu fibreux high-tech Enveloppe en PS équipée d'un support à crochets préinstallé, y compris rosettes et capot. Classe allemande de protection incendie B2. Couleur argent.

### IT TopShell

Isolamento in tessuto non tessuto high-tech. Mantello in skai pre-assemblato con cerniera, dotato di rosette e calotta di copertura. Classe di resistenza antincendio B2. Argento. Consegna sfusa.

### Alternativa

Isolamento in tessuto non tessuto high-tech. Mantello in PS e barra con ganci, rosette e calotta di copertura incluse. Classe di resistenza antincendio B2. Colore argento.

TopShell  
B2;  $\lambda = 0.038 \text{ W/(mK)}$

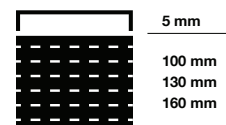

# Pufferspeicher

## Buffer storage tanks

### Ballon tampon

### Accumulatori tampone

Verwendung Usage   Utilisation   Uso		600	800	900	1000	1050	1250	1500	1600	1800	1950	2000	2500	3000	4000	5000	
TopShell 100	Wärmeverlust Heat losses Pertesthermiques Perdita di calore	kWh/24h	2.89	3.12	3.38	3.38	3.49	3.82	-	-	-	-	-	-	-	-	
		W	121	130	141	141	146	160	-	-	-	-	-	-	-	-	
	ErP-Label ErP class   Classe ErP   Classe ErP		C	C	C	C	C	C	-	-	-	-	-	-	-	-	
	CH   SIA 384/1 Ta ≤ 90°C		•	•	•	•	•	•	X	X	X	X	X	X	X	X	
	CH   SIA 384/1 Ta ≤ 50°C		•	•	•	•	•	•	X	X	X	X	X	X	X	X	
	EU   Nr. 814/2013 (EU)		•	•	•	•	•	•	X	X	X	•	•	•	•	•	
	A $\overline{H}$ [mm]		1700	1740	1820	2090	2050	2060	2200	1950	2205	2060	2420	2330	2770	2885	2920
	C Ø [mm]		900	990	1050	990	1050	1150	1200	1300	1300	1450	1300	1450	1450	1600	1800
	Art. Nr. 300107... Part no.   Réf.   Art.n.		0601	0801	0901	1001	1051	1251	1501*	1601*	1801	1951	2001	2501	3001	4001	5001
	TopShell 130	Wärmeverlust Heat losses Pertesthermiques Perdita di calore	kWh/24h	-	-	-	-	-	-	4.00	4.08	4.35	-	-	-	-	-
		W							167	170	182						
ErP-Label ErP class   Classe ErP   Classe ErP			-	-	-	-	-	-	C	C	C	-	-	-	-	-	
CH   SIA 384/1 Ta ≤ 90°C			•	•	•	•	•	•	•	•	•	X	X	X	X	X	
CH   SIA 384/1 Ta ≤ 50°C			•	•	•	•	•	•	•	•	•	X	X	X	X	X	
EU   Nr. 814/2013 (EU)			•	•	•	•	•	•	•	•	•	•	•	•	•	•	
A $\overline{H}$ [mm]			1730	1770	1850	2120	2080	2090	2230	1980	2235	2090	2450	2360	2800	2915	2950
C Ø [mm]			960	1050	1110	1050	1110	1210	1260	1360	1360	1510	1360	1510	1510	1660	1860
Art. Nr. 300107... Part no.   Réf.   Art.n.			0602*	0802*	0902*	1002*	1052*	1252*	1502	1602	1802*	1952*	2002*	2502*	3002*	4002*	5002*
TopShell 160		Wärmeverlust Heat losses Pertesthermiques Perdita di calore	kWh/24h	-	-	-	-	-	-	-	-	-	-	-	-	-	-
		W															
	ErP-Label ErP class   Classe ErP   Classe ErP		-	-	-	-	-	-	-	-	-	-	-	-	-	-	
	CH   SIA 384/1 Ta ≤ 90°C		•	•	•	•	•	•	•	•	•	X	X	X	X	X	
	CH   SIA 384/1 Ta ≤ 50°C		•	•	•	•	•	•	•	•	•	•	•	•	•	•	
	EU   Nr. 814/2013 (EU)		•	•	•	•	•	•	•	•	•	•	•	•	•	•	
	A $\overline{H}$ [mm]		1760	1800	1880	2150	2110	2120	2260	2010	2265	2120	2480	2390	2830	2945	2980
	C Ø [mm]		1020	1110	1170	1110	1170	1270	1320	1420	1420	1570	1420	1570	1570	1720	1920
	Art. Nr. 300107... Part no.   Réf.   Art.n.		0603*	0803*	0903*	1003*	1053*	1253*	1503*	1603*	1803*	1953	2003	2503	3003	4003	5003

Ta = Auslegungstemperatur

Ta = dimensioning temperature | Ta = température de conception | Ta = temperatura di progetto

 Zugelassen (Empfohlene Isolierung)  
Approved (Recommended insulation) | Agréée (Isolation recommandée) | Omologato (Isolamento consigliato)

 Zugelassen (oberhalb Mindestanforderung)  
Approved (Exceeds minimum requirements) | Agréée (Supérieure aux exigences minimales requises) | Omologato (Requisito minimo superiore)

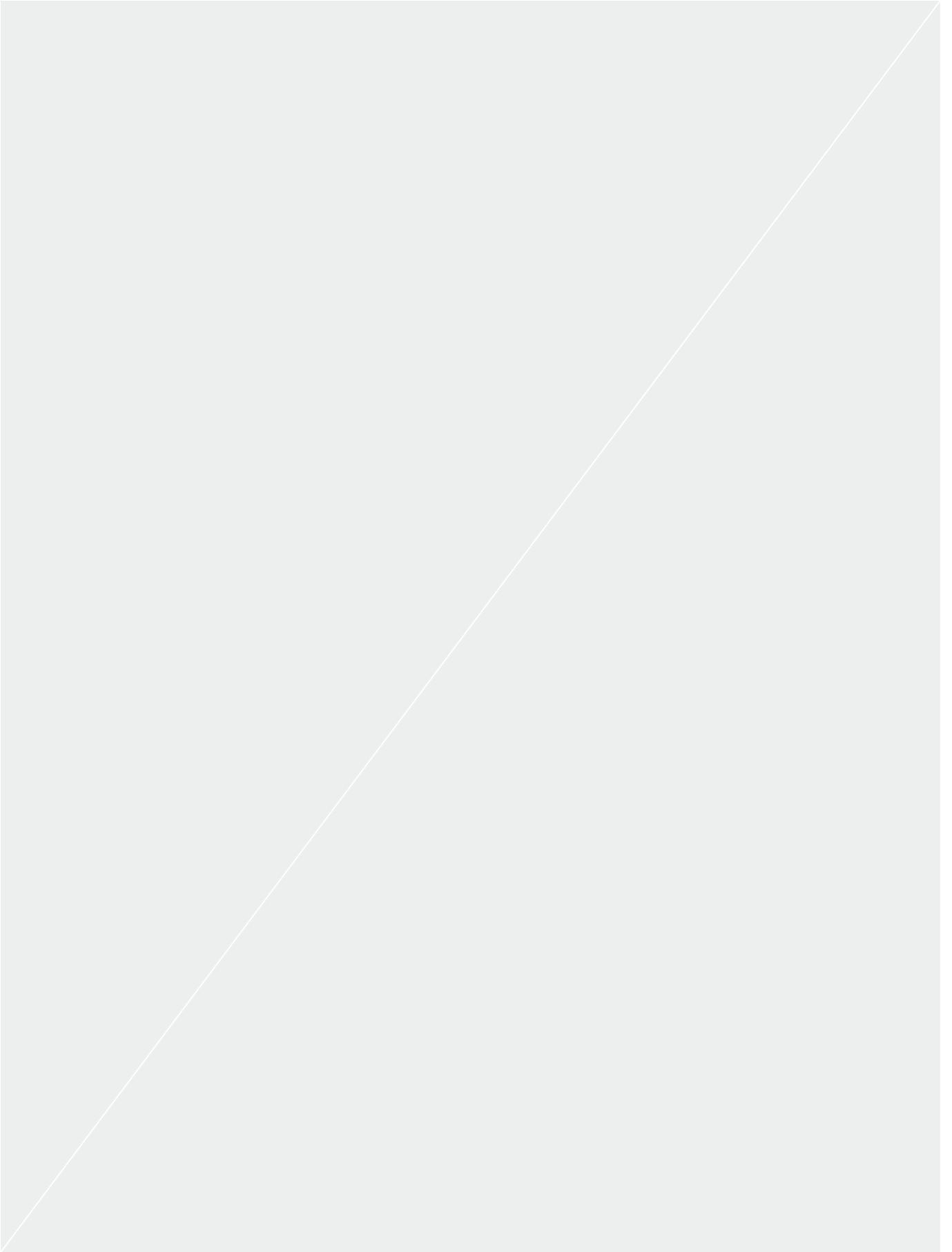

**Pufferspeicher**  
**Buffer storage tanks**  
**Ballon tampon**  
**Accumulatori tampone**

600 – 5000

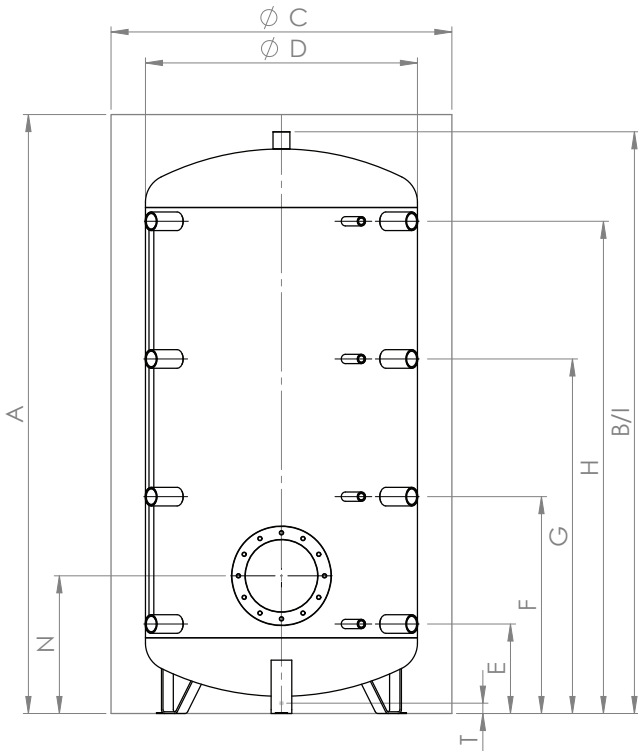

600 – 5000

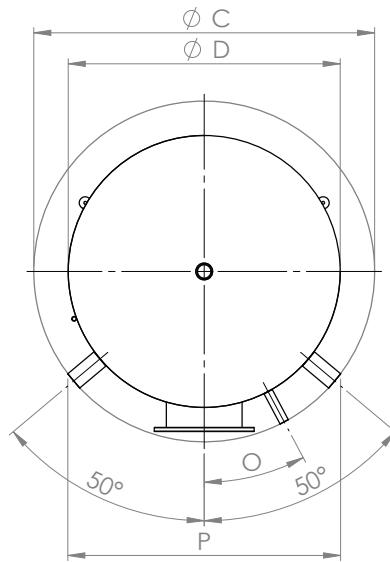

600 – 5000



	Verwendung Usage Utilisation Uso	Dimension Dimension Dimension Dimensione	600	800	900	1000	1050	1250	1500	1600	1800	1950	2000	2500	3000	4000	5000
	Inhalt Capacity   Contenance   Contenuto	l	560	718	870	887	996	1266	1500	1555	1830	2005	2021	2304	2852	3759	5003
	Kippmass Tilted dimension   Cote de basculement   Altezza in raddrizzamento	mm	1680	1720	1800	2070	2020	2030	2180	1940	2190	2050	2390	2310	2740	2880	2920
P	Einbringmass Delivery dimensions   Cote de mise en place   Ingombro	100 mm	730	800	840	800	840	950	1000	1100	1100	1250	1100	1250	1250	1400	1600
		130 mm	780	840	890	840	890	970	1010	1100	1100	1250	1100	1250	1250	1400	1600
		160 mm	820	890	940	890	940	1010	1060	1130	1130	1250	1130	1250	1250	1400	1600
B	Höhe ohne Isolierung Height without insulation   Hauteur sans isolation   Altezza senza isolamento	mm	1650	1685	1770	2040	1990	1998	2148	1902	2152	2007	2352	2267	2704	2835	2870
D	Ø ohne Isolierung without insulation   sans isolation   senza isolamento	mm	700	790	850	790	850	950	1000	1100	1100	1250	1100	1250	1250	1400	1600
E*	Anschluss 1 Connection   Raccord   Collegamento	- mm	230	260	310	310	310	310	380	320	320	495	320	535	380	505	400
		G"	1 1/2"	1 1/2"	1 1/2"	1 1/2"	1 1/2"	1 1/2"	2"	2"	2"	2"	2"	2"	2"	2"	2"
		- G"	1/2"	1/2"	1/2"	1/2"	1/2"	1/2"	1/2"	1/2"	1/2"	1/2"	1/2"	1/2"	1/2"	1/2"	1/2"
F*	Anschluss 2 Connection   Raccord   Collegamento	- mm	610	630	700	745	745	745	825	740	820	875	900	975	1020	1110	1100
		G"	1 1/2"	1 1/2"	1 1/2"	1 1/2"	1 1/2"	1 1/2"	2"	2"	2"	2"	2"	2"	2"	2"	2"
		- G"	1/2"	1/2"	1/2"	1/2"	1/2"	1/2"	1/2"	1/2"	1/2"	1/2"	1/2"	1/2"	1/2"	1/2"	1/2"
G*	Anschluss 3 Connection   Raccord   Collegamento	- mm	990	1030	1080	1250	1250	1250	1350	1150	1320	1255	1490	1415	1680	1860	1810
		G"	1 1/2"	1 1/2"	1 1/2"	1 1/2"	1 1/2"	1 1/2"	2"	2"	2"	2"	2"	2"	2"	2"	2"
		- G"	1/2"	1/2"	1/2"	1/2"	1/2"	1/2"	1/2"	1/2"	1/2"	1/2"	1/2"	1/2"	1/2"	1/2"	1/2"
H*	Anschluss 4 Connection   Raccord   Collegamento	- mm	1380	1430	1470	1710	1710	1710	1760	1570	1820	1635	2020	1855	2330	2410	2520
		G"	1 1/2"	1 1/2"	1 1/2"	1 1/2"	1 1/2"	2"	2"	2"	2"	2"	2"	2"	2"	2"	2"
		- G"	1/2"	1/2"	1/2"	1/2"	1/2"	1/2"	1/2"	1/2"	1/2"	1/2"	1/2"	1/2"	1/2"	1/2"	1/2"
I	Anschluss oben Connection above   Raccord du haut   Collegamento superiore	- mm	1650	1685	1770	2040	1990	1998	2148	1902	2152	2007	2352	2267	2704	2835	2870
		G"	1 1/4"	1 1/4"	3/4"	1 1/4"	1 1/4"	1 1/4"	1 1/4"	1 1/4"	3/4"	1 1/4"	1 1/4"	1 1/4"	1 1/4"	1 1/4"	1 1/4"
N	Flansch Flange   Bride   Flangia	- mm	330	400	400	400	400	395	450	425	425	585	425	755	600	595	640
		Ø - mm	290/220														
T	Bodenmuffe Ground fitting   Manchon de fond   Manicotto a pavimento	- mm	-	-	-	-	-	-	-	-	-	123	-	123	110	75	50
		G"	-	-	-	-	-	-	-	-	-	1 1/4"	-	1 1/4"	1 1/4"	1 1/4"	1 1/4"
O	Anordnung Fühler Positioning sensor   Disposition sonde   Disposizione sensore	°	28.0	28.0	29.8	28.0	29.8	32.0	33.0	34.5	34.5	36.0	34.5	36.0	36.0	37.5	39.0
	Gewicht Weight   Poids   Peso	kg	84	97	100	111	117	158	168	174	180	227	201	239	285	364	431
	Max. Einbaulänge von Elektroheizungen Max. installation length of electric heaters   Longueur maximale d'installation des chauffages électriques   Lunghezza massima di installazione dei riscaldatori elettrici	mm	700	790	850	790	850	950	1000	1100	1100	1250	1100	1250	1250	1400	1600

\*Einbaumöglichkeit: 1 x Elektroheizung zum Einschrauben  
Installation option: 1 x Screw-in Immersion heater | Option d'installation: 1 x Résistances à visser | Opzione di installazione: 1 x Resistenza elettrica da avvitare