

WICHTIG: Kältemittel R32 mit der Sicherheitsklasse A2L (SN EN 378-1 grenzwert 0.061 kg/m³)

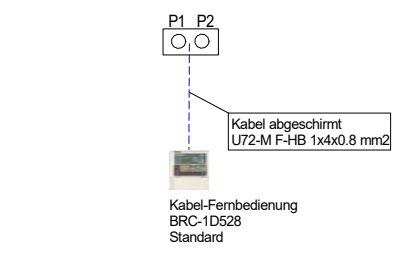
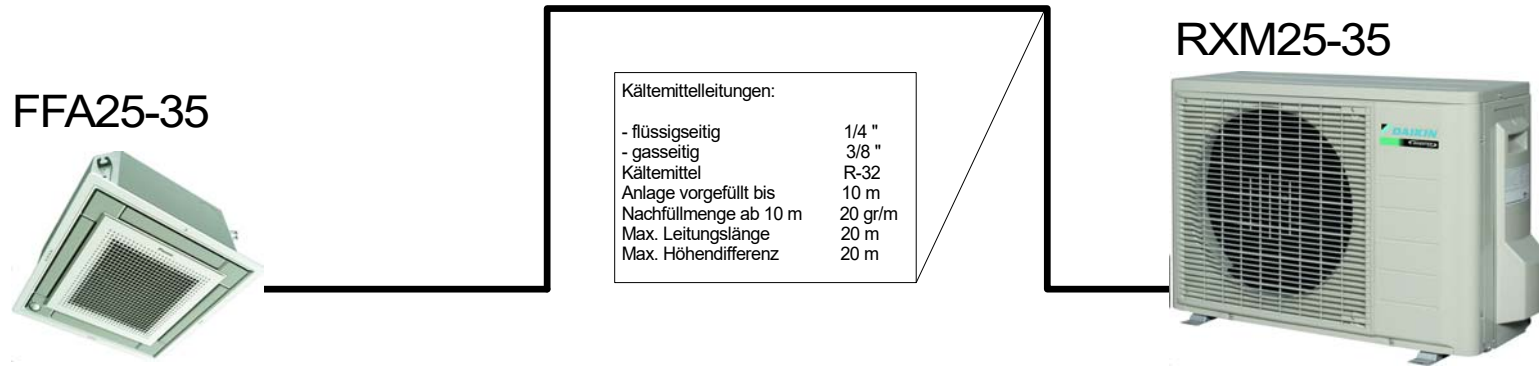

Elektroanschluss:
Gemäss örtlichen Vorschriften!

Speisung
230V / 50Hz 13 A träge

Anlage mit sep. Hauptschalter versehen!

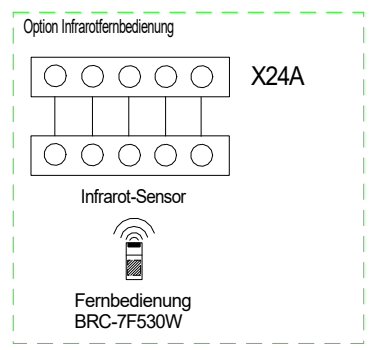

	RXM-25	RXM-35
Ausseneinheit		
Kühlleistung max.	2.5 kW	3.5 kW
Kältemittelmenge	0.76 kg	0.76 kg
Absicherung	13AT	13AT

RXS25-35 + FFA25-35

Elektro und Kälteschema

TCA Thermoclima AG	Piccardstrasse 13 9015 St. Gallen www.tca.ch	Tel 071 313 99 22 Fax 071 313 99 29 info@tca.ch
---------------------------	--	---