

**WICHTIG: Kältemittel R32 mit der Sicherheitsklasse A2L (SN EN 378-1 grenzwert 0.061 kg/m<sup>3</sup>)**

**RZASG100-125-140Y**

**FHA100-125-140**

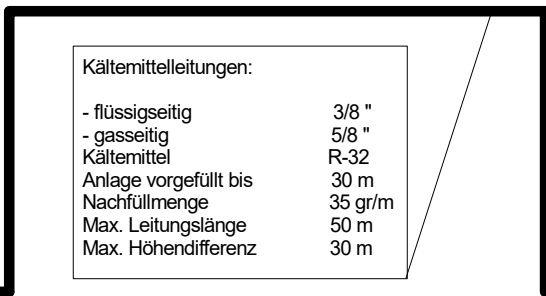

Kabel abgeschirmt  
U72-M F-HB 1x4x0.8 mm<sup>2</sup>

Kabel-Fernbedienung  
BRC-1D528  
Standard

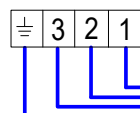

Verbindungsleitung Kommunikation Kabel 4 x 1.5mm<sup>2</sup>

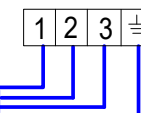

L1 L2 L3 N E



Elektroanschluss:

Gemäss örtlichen Vorschriften!

Speisung  
3 x 400 V / 50 Hz / siehe Angaben Absicherung

Anlage mit sep. Hauptschalter versehen!

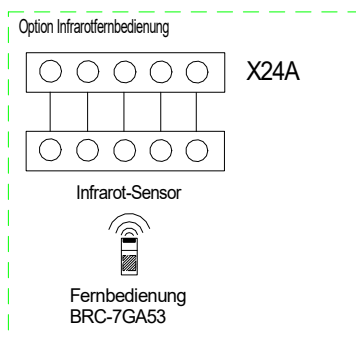

Ausseneinheit	RZASG-100Y	RZASG-125Y	RZASG-140Y
Kühlleistung max.	10.0 kW	12.0 kW	13.4 kW
Kältemittelmenge	2.6 kg	2.6 kg	2.9 kg
Absicherung	400V 16AT	400V 16AT	400V 16AT

**RZASG100-140 + FHA100-140**  
**Elektro und Kälteschema**

**TCA Thermoclima AG**

Piccardstrasse 13  
9015 St. Gallen  
www.tca.ch

Tel 071 313 99 22  
Fax 071 313 99 29  
info@tca.ch